

InkRollCleaner

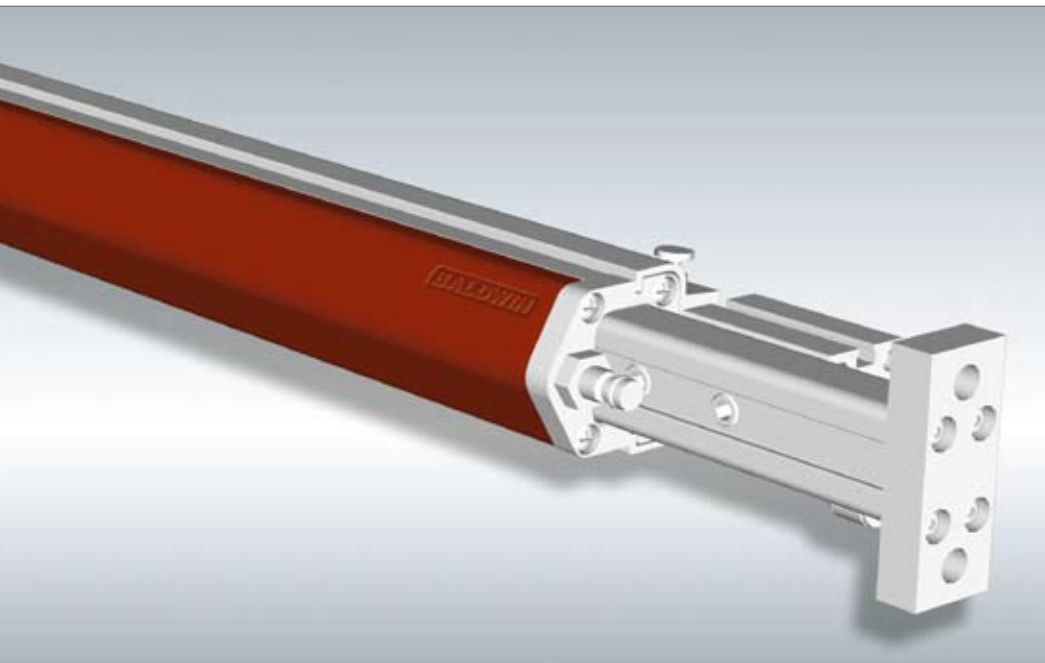

Precision performance with unique clog-free technology



The latest technology for ink train cleaning prevents clogging of the holes in the spray tube caused by ink misting. Baldwin's patented gate function covers the spray tube between cleaning cycles while the press is in production.

InkRoll Cleaner activates automatically when there is a need for cleaning and the flexible spray bars can be angled for precise application. By cleaning all the ink rolls at the same time, the system allows you maximum availability of the press and increased production.



With its compact design, the InkRollCleaner is easy to install and operate, has low maintenance, hazard-free handling, and, as always, the Baldwin guarantee for best-quality results.

Advantages

Practical

- Mist cover protection prevents clogged spray bar
- Reduced handling of hazardous solvents in press room
- Few system components for simple installation and low maintenance
- Compact design for easy fit into any press
- Low-pressure system (2 bars) for minimal fluid misting

Economical

- All ink train positions cleaned in less than 3 minutes
- 90% less solvent consumption compared with manual wash
- Improves quality and frees valuable press time
- Lower costs for cleaning agents

Ecological

- Reduces the use of environmentally hazardous solvents
- No manual handling of the cleaning agents



Innovative Ink Train Cleaning

The Baldwin InkRollCleaner system offers state-of-the-art technology as a precise and economical method for cleaning the ink trains. The unique, patented gate on the spray bar covers the spray bar preventing contamination of the spray orifices during production

The InkRollCleaner cleans all ink trains at the same time in a customized spray sequence where also the scraper blade, ink form roller, water form roller and damp roller are controlled, increasing press production time. The cleaning fluid is distributed evenly over the adjacent rollers through a number of adjustable spray orifices on the bar for precise application. The scraper blade mounted in the press removes the ink and cleaning agent from the ink train. With its compact, hazard-free design the InkRollCleaner has few system components allowing user-friendly installation, operation and maintenance.

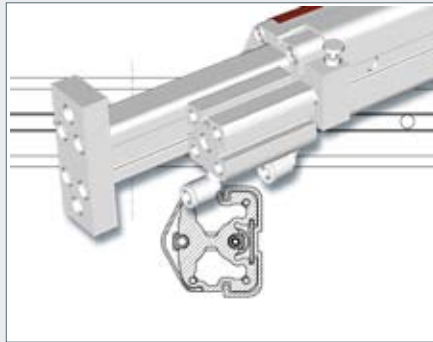

The patented gate function covers the spray tube

The automatic InkRollCleaner increases press production, enhances the working environment and lowers your costs of operation.

Technical Description

<i>Mounting angles</i>	$\pm 60^\circ$
<i>Spray distance</i>	50-100mm
<i>Widths</i>	< 2500mm
<i>Spray object</i>	Nip or roller surface
<i>Solvent viscosity</i>	< 10mpas and Fogra approved
<i>System capacity</i>	48 spray bars/Pumping unit

Service solutions

- Can be integrated with the pump system for your ImpactFusion-F system

BALDWIN – complete printing periphery in one system

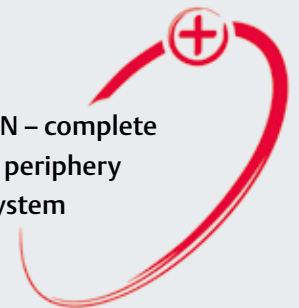

Contact us for:

- Professional advice
- Request for further information
- Return on investment calculation (ROI)

